

SUZIE 90 H.P. MARINE DIESEL



Suzie
DIESEL

4JG1T RATINGS:

Intermittant at sealevel (60 degrees)
90 b.h.p. @ 3000 r.p.m.
 Continuous at sealevel (60 degrees)
80 b.h.p. @ 2800 r.p.m.
 Torque at sealevel (60 degrees)
192 ft.lbs. @ 1800 r.p.m.



ENGINE SPECIFICATIONS	MARINE GEAR SPECIFICATIONS
Model Number: Isuzu 4JG1T Type: Four stroke, water cooled 4 cylinder Combustion: Direct injected, induction swirl Bore & Stroke: 85 mm x 96 mm Piston Displacement: 3.1 litres Engine Rotation: Counter Clockwise facing flywheel Dry Weight: 560 lbs.(254 kg.). With Gear: 610 lbs.(278kgs.) Lube Oil Capacity: 7.5 litres Coolant Capacity (engine only): 5.3 quarts (5 litres) Aspiration: Turbo Charged	Model: Hurth HBW 450a* Engagement: Mechanical Gear Housing: High strength aluminum Prop Rotation: Left hand or right hand** Reduction: Choice of 1.5, 2.0, 2.5, to 1 Oil Grade: ATF * <i>Optional Borg Warner, or gear of choice.</i> ** <i>Gear cooler may be required</i>

ENGINE AND MARINE GEAR DIMENSIONS

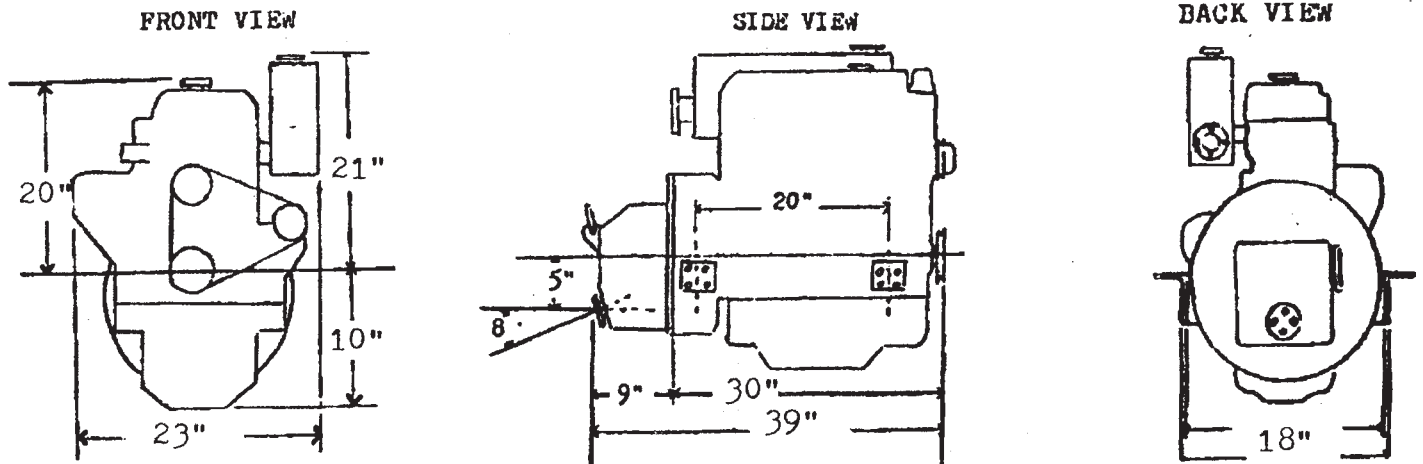

VISIT OUR WEBSITE: www.klassenengine.com

4JG1T FEATURES AND ACCESSORIES

12 VDC electrical with gear reduction starter

Glow plug assist starting

SAE#4 bellhousing with SAE 10in. overcentre flywheel

Replaceable chromard dry liners

Direct injection with square combustion chambers for efficiency

Auto-thermic pistons minimize heat expansion and wear for extended life

Available bobtail or complete with gear

STANDARD ACCESSORIES

- Set up for keel cooling
 - 51 AMP stock alternator
 - Intake plenum with air cleaner
 - Steel footings with isolators
 - Engine oil change pump
 - *Water cooled dry exhaust manifold*
 - Lube oil and secondary fuel filters
 - 15 ft pre-wired gauge panel with:
Tach with hour meter, oil p.s.i., water temperature, volt or amp meter, key start, glow plug indicator
 - Low oil, high temp alarm system
- *Available with or without expansion tank*

OPTIONAL ACCESSORIES

- 105 or 130 amp alternator upgrades
- 10ft. or 20ft. wire harness extensions
 - Electrical stop solenoid
 - Dual station
- Bellhousing to gear adapter plate
 - Standard drive disc
- Heat exchanger kit, which includes:
 - 1) remote or engine mounted heat exchanger
 - 2) belt driven or direct coupled half inch water pump
Jabsco raw water pump
 - 3) optional exhaust mixing elbow

HORSEPOWER AND FUEL CONSUMPTION CURVES:

RATED OUTPUT : 83 hp / 2500 rpm
 MAXIMUM TORQUE : 192 lb·ft / 1800 rpm

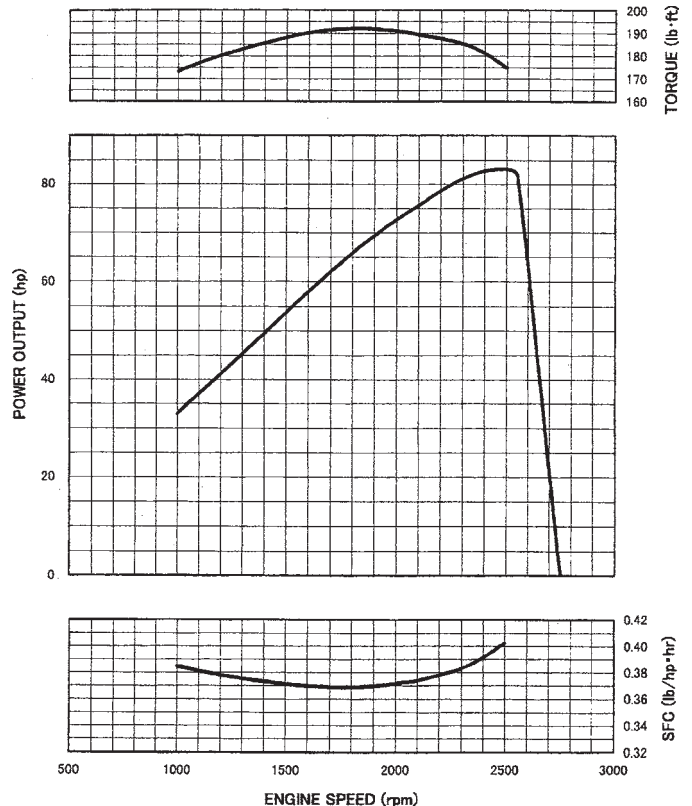

KLASSEN ENGINE CO.

1538 NW 50 TH ST.
 SEATTLE, WA. 98107
 TEL. (206) 784-0148
 FAX. (206) 783-6811
 TOLLFREE 1-888-784-0148
 E-MAIL: seattle@klassenengine.com

KLASSEN DIESEL SALES

#101-7187 PROGRESS WAY
 DELTA, BC, V4G-1K8
 TEL. (604) 940-6400
 FAX. (604) 940-6500
 E-MAIL: delta@klassenengine.com

KLASSEN DIESEL SALES

6701 OLDFIELD RD.
 SAANICHTON, BC, V8M-2A1
 TEL/FAX (250) 652-6655
 E-MAIL: victoria@klassenengine.com